

AquaScooter2

By

Dylan Cannon, Darin Gilliam, Eli Palomares, Elizabeth Tyler,
Jiyan Wang, Tyler Winston
Team 8

Progress Report Document

*Submitted towards partial fulfillment of the requirements for
Mechanical Engineering Design I – Spring 2015*



Department of Mechanical Engineering
Northern Arizona University
Flagstaff, AZ 86011

ABSTRACT

The Aqua Scooter currently has a two cycle gas powered engine that, as of January 2010, the EPA's regulations prevent future sales. The capstone team is tasked with designing and analyzing different alternative engine options, which meet current and immediate future EPA regulations.

Information pertaining to the emissions requirements and the current technology is provided along with the constraints given by the client. The team proposes in this progress report several options for emissions testing. Additionally, there are potential experiment procedures the team can conduct to measure thrust and test the viability of alternate fuels on the purchased engine. Finally, a schedule of deliverables for the second semester of the project is given.

Table of Contents

Contents

TABLE OF CONTENTS.....	III
<u>1.0 INTRODUCTION.....</u>	<u>1</u>
1.1.1 PRODUCT AND CLIENT INFORMATION	1
1.1.2 BACKGROUND	2
1.1.3 AQUA SCOOTER EMISSIONS.....	3
1.1.4 WHY TEST FOR EMISSIONS	3
1.2.1 CURRENT TECHNOLOGY	3
1.2.2 MATERIAL PROPERTIES.....	4
1.2.3 POSSIBLE SOLUTIONS.....	4
1.2.4 SUMMARY.....	4
<u>2.0 PROBLEM STATEMENT.....</u>	<u>5</u>
2.1. CONSTRAINTS.....	5
<u>3.0 GANTT CHART.....</u>	<u>6</u>
<u>4.0 ENGINE ANALYSIS.....</u>	<u>6</u>
4.1.1 GASOLINE ANALYSIS.....	7
4.2.1 PROPANE AND BUTANE ANALYSIS.....	8
4.3.1 VOLUME ANALYSIS	8
4.3.2 THRUST ANALYSIS.....	8
4.3.3 DRY COMBUSTION ANALYSIS.....	9
<u>5.0 FINAL ENGINE SELECTION.....</u>	<u>11</u>
<u>6.0 SHELL ANALYSIS.....</u>	<u>11</u>
6.1.1 BOOMERANG.....	12
6.1.2 TRITON	13
6.2.1 POWER CALCULATIONS FOR BOOMERANG AND TRITON	14
6.3.1 SHELL CONSTRUCTION.....	14
<u>7.0 CONVERSION KIT.....</u>	<u>14</u>
<u>8.0 TESTING.....</u>	<u>15</u>
8.1.1 TESTING FACILITY	15
8.2.1 POWER OUTPUT TESTING.....	16
8.3.1 THRUST OUTPUT TESTING.....	17
8.4.1 EMISSIONS TESTING	18
<u>10.0 COST ANALYSIS.....</u>	<u>19</u>

11.0 CONCLUSION.....21

List of Figures and Tables

Figures

Figure 1: Aqua Scooter with Components.....	1
Figure 2: Aqua Scooter with Components and Extension.....	2
Figure 3: Gantt Chart.	6
Figure 4: Current engine and proposed 4-stroke engine.....	7
Figure 5: Honda GX25 4-Stroke Engine.....	11
Figure 6: Example coefficients of drag and corresponding shapes.....	12
Figure 7: Final boomerang design with handlebars on the top.....	13
Figure 8: Final Triton design modeled after teardrop concept.....	13
Figure 9: Propane Conversion Kit Components.....	15
Figure 10: Fish Tank for Thrust and Power Testing.....	16
Figure 11: Trough for Thrust and Power Testing.....	16
Figure 12: Prony Brake Setup.....	17
Figure 13: 5-Gas Analyzer.....	18
Figure 14: Pie Chart with Percentages of Total Cost.....	21
Figure 15: Possible engine design converted for gas fuel.....	22
Figure 16: Final Triton design with area used for analysis.....	22
Figure A1: Components Description.....	38
Figure A2: Components Description.....	38

Tables

Table 1: Cost of Materials for Testing Engine Solutions

20

1.0 INTRODUCTION

1.1.1 Product and Client Information

Aqua Scooter is a portable, submersible, gasoline powered water craft for individual use. Aqua Scooter is family owned and operated out of Sedona, Arizona. The client for this project R.S.W. /D.I. Inc is the owner and CEO of Aqua Scooter. The current device design is shown in Figure 1 and Figure 2. The numbered component descriptions are found in the Appendix of this report. The design incorporates a 2-stroke engine which provides approximately 2HP of power to the user. The scooter provides around 5 hours of operating time with a 2 L fuel tank capacity.

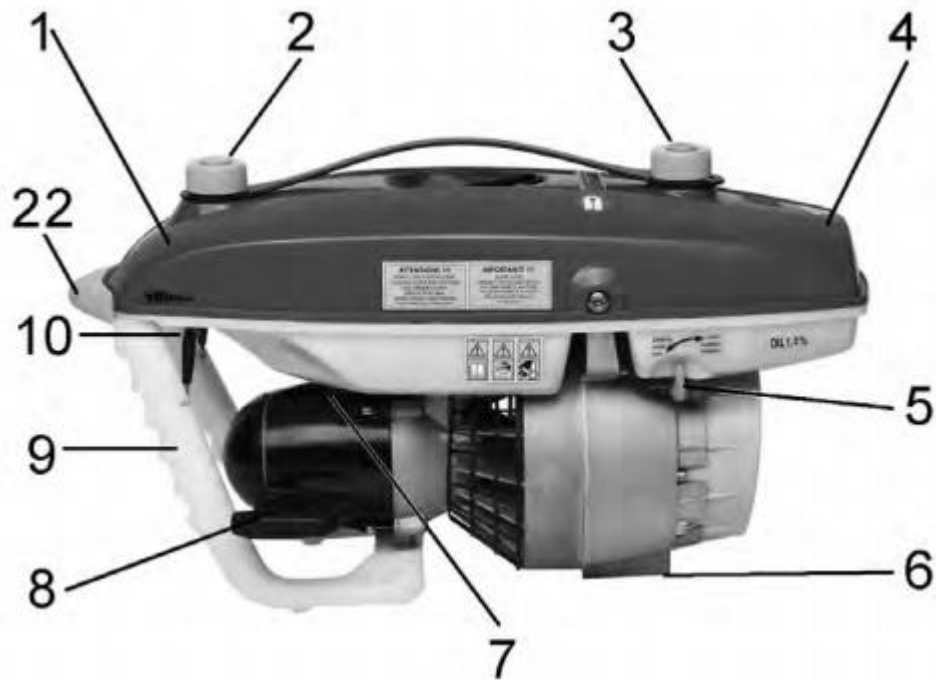

Figure 1: Aqua Scooter side view with designated components

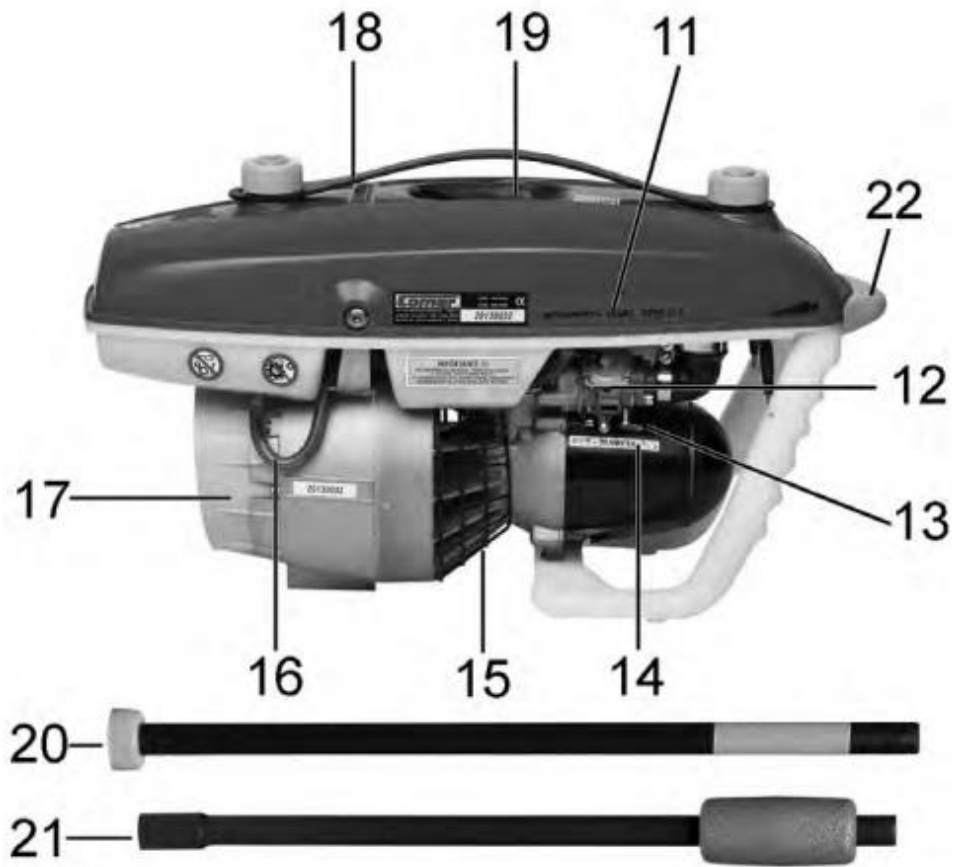

Figure 2: Aqua Scooter with designated components and snorkel extension

1.1.2 Background

A chemical technician by the name of Bernd Boettgers wanted to escape from East Germany, but he knew he would need some type of machine to help pull him through the sea. His first attempt to test his “water-machine” resulted in an arrest and jail time of three months. He was convicted of an illegal attempt at border crossing. After he was released, he decided to work on a second machine, and after a year of building, he entered the sea in September of 1968 for his second attempt. He traveled by water for six hours, two of which were done fully submerged under the sea, until he was finally spotted by the Danish Lightship, named Gedser. His successful escape broke into the European Press, and by the end of January in 1978 the “Aqua Scooter” had been brought to the United States and the first commercial prototype was successfully tested.

1.1.3 Aqua Scooter Emissions

The current 2-stroke, direct drive engine does not comply with EPA regulations. As a result, the client is unable to sell the Aqua Scooter in the United States. The current emission standards that the Aqua Scooter must meet are as follows:

- It must have less than or equal to 30 g of hydrocarbons
- Less than or equal to 490 g of carbon monoxide per kilowatt hour.

Emissions testing will be done by either the Arizona Department of Transportation, or Arizona Game and Fish Department.

1.1.4 Why Test for Emissions

A good question one might find themselves asking, is why test for emissions? What benefits does it bring to the customer, if any, and why is it important to pass? It turns out that passing an emissions test and just taking the test in general, brings several advantages. Here are three reasons why emissions testing are very important:

1. It identifies necessary repairs to improve vehicles performance and fuel economy
2. It improves air quality by reducing carbon monoxide, hydrocarbons, and nitrogen oxides
3. If emission controls are not working properly, testing ensures that owners make the appropriate repairs to aid in the reduction of ground level ozone

Although testing for emissions improves the air quality for everyone around you, it also turns out that emission testing also brings several benefits to the customers themselves.

1.2.1 Current Technology

The group researched two and four stroke engines for this project. The current technology on the market is available to implement in a possible solution for our client. Options available in the current market are conventional gas models or alternatives such as propane or compressed natural gas.

1.2.2 Material Properties

The materials for the new design need to be lightweight so that the Aqua Scooter can float.

The new scooter should also have materials strong enough to support its own weight and handle the pressure exerted when submerged to maximum operating depth. The manufacturing of the device will also need to be considered when selecting the materials so that the cost of making the new design is still feasible.

1.2.3 Possible Solutions

Current solutions to the problem are either a four stroke internal combustion engine or a fuel injected two stroke internal combustion engine. The issue with the four stroke solution is implementing an engine that is light enough to meet the weight and thrust constraints.

Research to resolve this issue has been focused primarily on compressed fuels contained in cylinders. There may be an advantage in losing the weight of a gas tank to lighten the overall weight of the machine. As for the two stroke solution, current technology is available that monitors and controls fuel intake to minimize the unburned amounts of fuel that enter the atmosphere as seen with previous two stroke models. Fuel system modification, along with implementing biodegradable two stroke oils that are also recently available, can be a viable solution in designing a product that meets current EPA requirements.

1.2.4 Summary

The Aqua Scooter is a machine that has been useful for over four decades. The power system that the machine has used since its origin is obsolete based on current environmental regulations. In order for the Aqua Scooter to keep fulfilling the legacy it has created, the team has been tasked with redesigning the device. This will be accomplished through testing and implementation of state of the art technology in the field of materials, as well as internal combustion engines.

2.0 PROBLEM STATEMENT

The current design for the Aqua Scooter does not comply with the most recent Environmental Protection Agency's regulations on two-stroke engines for recreational use. In order to have a marketable product, this team will design a hydrodynamic, inexpensive, aesthetically pleasing Aqua Scooter, with a marine engine that complies with EPA regulations.

2.1. Constraints

The prototype needs to meet certain constraints the team has determined based off communication with the client. The constraints are the following:

- Gasoline powered
- Engine housing must be metal
- Muffler housing must be metal
- Throttle control
- Exhaust valve
- Starter assembly made of plastic and metal
- Plastic propeller protection
- Control handle
- Plastic fuel tank, with minimum volume of ½ gallon
- Must have a dry weight of 18 lbs. or less
- Must be buoyant enough to float itself
- Must provide at least 50 lbs. thrust
- Must cost no more than \$450 per scooter manufactured

3.0 GANTT CHART

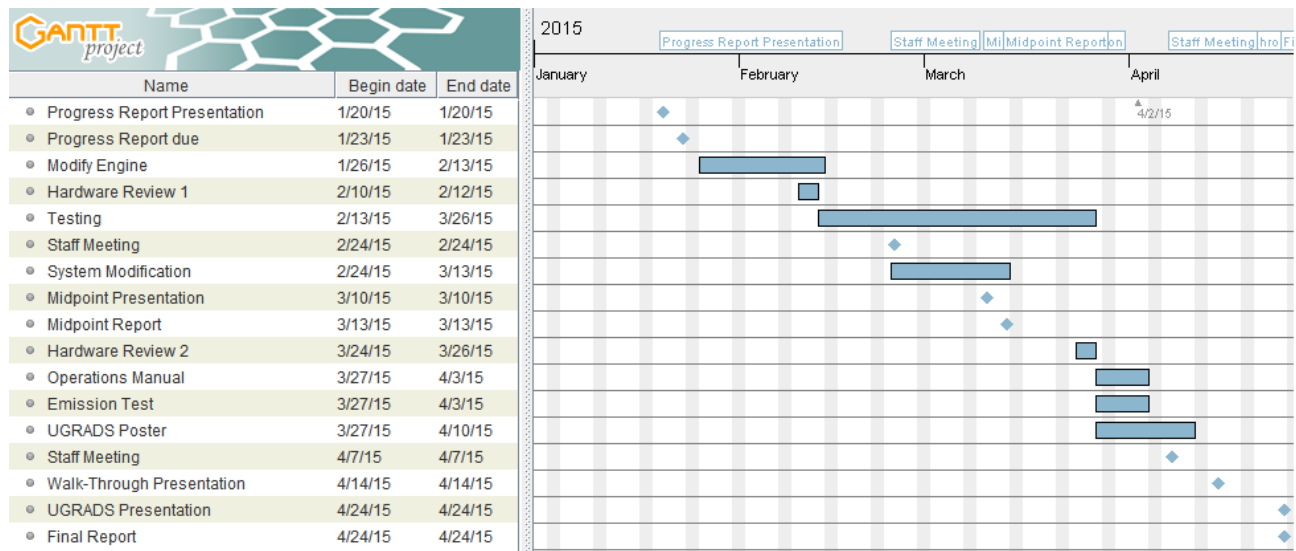

Figure 3: Gantt Chart and schedule of major deliverable and tasks for project.

Figure 3 displays the Gantt chart which illustrates an estimated timeline for the first semester of the Aqua Scooter prototype design. The timeline is broken down into tasks and deliverables. Tasks are shown as blue bars and deliverables are shown as blue diamonds in Figure 3. The deliverables include presentations and reports. Based on the materials required for the presentations, the tasks are laid out in an order such that tasks relevant to specific presentations are completed before the presentation date. This layout ensures everything is completed while also ensuring there are specific timelines for certain tasks. The Gantt chart is the schedule the team will keep to, to ensure the project is completed on time.

4.0 ENGINE ANALYSIS

The main objective of this report is to analyze and compare the use of propane and butane with gasoline in a 4-stroke engine. Along with alternative fuels, the drag coefficients of the final two shell designs were calculated, as well as the drag force that

each of the shells experience at the required velocity. Finally, the propeller was designed to meet the thrust requirement prescribed by the client.

4.1.1 Gasoline Analysis

The main objective for the team is to create prototype that will meet and surpass the current and known future EPA regulations for marine engines. After some initial analysis, the team decided to pursue a design which included a 4-stroke engine. The 4-stroke Honda GXH50 engine shown in Figure 4, engine currently complies with the EPA regulations. This engine will be analyzed as a foundation for all calculations in the report. This 4-stroke engine has an intake stroke, compression stroke, power stroke, and exhaust stroke. The extra 2 strokes in the 4-stroke engine result in fewer emissions and a higher percentage complete combustion of fuel. There are currently many EPA approved 4-stroke engines on the market today, so that is the direction we chose.

Dimensions	Aqua Scooter 2-Stroke Engine (AS 650)	4-Stroke Engine (Honda GXH50)
Length (mm)	530	225
Width (mm)	195	274
Height (mm)	320	353
Weight (lb)	16.53	12.1
Bore (mm)	40	41.8
Stroke (mm)	39	36
Displacement (cc)	49	49.4
Power (HP)	2	2.1 @ 7000rpm
Thrust (kg)	22	22
Fuel	Mixture	Unleaded 86 Octane or Higher
Fuel Tank Capacity (L)	2	1.89271
Price (\$)	(+/-) 970	420



Figure 4: Current engine and proposed 4-stroke engine

In the figure shown above, the existing (entire) Aqua Scooter is displayed on the left, and the Honda GXH50 4-stroke engine is shown on the right. This is a potential 4 stroke engine on which we will base our calculations. The Honda engine is both wider and taller than the entire existing Aqua Scooter, so the shell will need to be redesigned in order to accommodate the larger engine size. Also, despite the 7000 rpm capability of the Honda motor, for the desired application it will be running at less than or equal to 80% of maximum rpm. Because of this, for all future calculations we assumed a horsepower of 5600 rpm. The price of the new Aqua Scooter (with a Honda 4-stroke engine) will be considerably higher than \$420 because only the engine is measured. However, since the engine is the most costly part, the total cost of manufacturing should not exceed the \$970 price of the current Aqua Scooter.

4.2.1 Propane and Butane Analysis

Although moving forward with a design that includes a standard octane fuel for a 4-stroke engine is a viable concept, alternate fuels are being analyzed. The client stated interest in butane and propane engines when presented with the concepts; therefore, the team worked to show that these fuels were feasible. The fuels were put through volume, thrust, combustion, and adiabatic analysis.

4.3.1 Volume Analysis

Volume analysis was conducted in order to verify the fuel would be capable to provide the amount of thrust required by the client. Additionally, the amount of butane and propane required and the weight were both major concerns in the design of the Aqua Scooter. It was necessary to prove that these two gases and the sizes of the correct volume containers needed would be feasible for the client requirements.

- Calculated weight of propane is 12.52 ounces.
- Calculated weight of butane is 12.50 ounces.

4.3.2 Thrust Analysis

The thrust analysis uses the following velocity equations:

$$T = \dot{m}V_e - \dot{m}V_0 \quad (1)$$

$$\dot{m} = \rho V_i A \quad (2)$$

$$T = \rho V_i A (V_e - V_0) \quad (3)$$

$$T = A \Delta p \quad (4)$$

$$T = 2\rho A V_i^2 \quad (5)$$

Equations 1 and 2 can be manipulated to produce thrust based on density of fluid, disk area of the propeller, and velocity of fluid immediately after the propeller (V_i), entering water velocity (V_0), and exiting water velocity (V_e) as shown in equation 3. Using equation 3 and 4 it can be shown that V_i is twice that of the V_e . This relationship allows for thrust to be determined based on area, density and V_i . The mathematical model used assumes the craft moves through relatively still water due to the nature of being a low speed recreation vehicle and therefore V_0 is assumed to be zero. Thrust and V_e are based upon client desires for the final project. The area of the propeller is an estimation for an appropriately sized propeller for a personal water craft, which will move at low speeds.

$$V_0 = 0$$

$$V_e = 2.235 \frac{m}{s}$$

$$A = .0324 m^2$$

$$T = 222 N$$

$$V_i = \sqrt{\frac{T}{2\rho A}} = 2.593 \frac{m}{s} \quad (6)$$

This value for V_i reinforces the fact that an appropriately designed engine pair with an appropriately designed propeller should adequately power the redesigned Aqua Scooter.

4.3.3 Dry Combustion Analysis

Dry combustion analysis is the best way to compare different fuel types against conventional octane that fuels majority of 4 stroke engines on the market. For dry combustion analysis stoichiometry must be computed for each theoretical chemical

combustion to determine the air to fuel ratio (AF). For convenience the stoichiometric analysis is done to have the fuel's coefficient to be one so the AF number is easier to compare with the AF ratio for octane of 15.1 (11).

Propane stoichiometry:

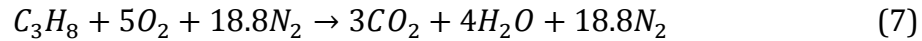

Butane stoichiometry:

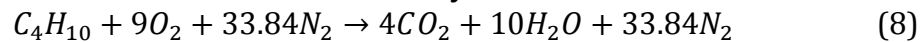

Air Fuel ratio for ideal combustion equation:

$$AF = \frac{\text{moles of air}}{\text{moles of fuel}} * \frac{M_{air}}{M_{fuel}} \quad (9)$$

AF ratio for propane

$$M_{air} = 28.97 ; M_{propane} = 44.09$$

$$AF_{propane} = (5 + 18.8) * \frac{28.97}{44.09} = 15.66 \frac{lb\ air}{lb\ propane} \quad (10)$$

AF ratio for butane

$$M_{air} = 28.97 ; M_{propane} = 58.12$$

$$AF_{butane} = (9 + 33.84) * \frac{28.97}{58.12} = 21.36 \frac{lb\ air}{lb\ butane} \quad (11)$$

As the above math shows the air to fuel ratios for propane and butane do no matter significantly when compared to that of octane. For this reason an adiabatic flame temperature calculation was determined to help determine which of the potential fuels would be the best alternative to octane. Adiabatic flame temperatures are determined using interactive thermodynamics equation solver software shown in Appendix D.

Examination of the adiabatic flame temperatures of products for the dry analysis of propane, butane and octane shows that the temperatures, which correlate with the fuel's ability to drive a piston in an engine, are similar given the same conditions (Appendix D). However it should be noted that dry combustion analysis and adiabatic flame temperatures are based on ideal conditions and are only used to help the design team make informed decisions without the ability to test a given fuel. With the above information it has been determined that propane would be an adequate fuel when paired with an engine designed to run on propane.

5.0 FINAL ENGINE SELECTION

A primary objective for next semester is to convert a 4 stroke and 2 stroke engine to run on a cleaner burning propane fuel. As of now, the team has purchased the 4 stroke engine; however there are two, 2 stroke engine options that the group is still considering.

The selected 4 stroke engine testing option is the Honda GX-25 multi- purpose utility engine. The GX-25 has a displacement of 25 cm³. The cost of the engine before shipping was \$240.00. The only drawback to the engine is the availability of replacement parts. The purchased conversion kit is designed specifically for the purchased engine making the engine modification more efficient.



Figure 5: Honda GX-25 4-Stroke Engine

6.0 SHELL ANALYSIS

Initially, the shape of the outer shell was similar to a boomerang. After estimating the drag force that the Aqua Scooter would experience with the boomerang as the shell, it was determined that a reiteration of the design was necessary to decrease the drag force. The formula for the drag force is dependent upon the drag coefficient which has been estimated for various shapes. Drag coefficients along with the formula can be seen below:

$$F=0.5\rho V^2 C_d A \quad (12)$$

Where:

$F = \text{Drag force [N]}$

$\rho = \text{Density [kg/m}^3]$

$V = \text{Velocity [m/s]}$

$C_d = \text{Drag Coefficient [unitless]}$

$A = \text{Area orthogonal to flow [m}^2]$

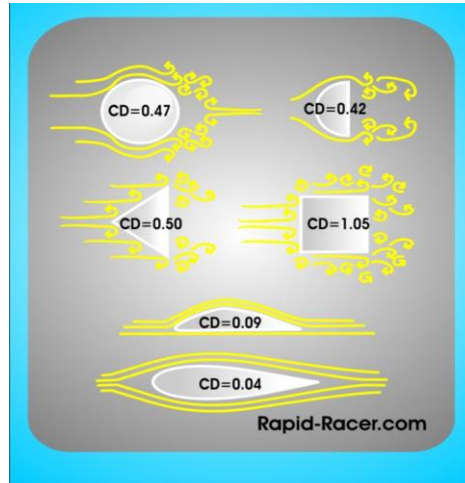

Figure 6: Example coefficients of drag and corresponding shapes

6.1.1 Boomerang

Coefficient of Drag Assumptions

$$C_d = 0.5$$

$$A = 1106.3 \text{ in}^2 = 0.714 \text{ m}^2$$

$$\rho = 999 \frac{\text{kg}}{\text{m}^3}$$

$$V_e = 2.235 \frac{\text{m}}{\text{s}}$$

Coefficient of Drag Calculations

$$F = 0.5\rho V^2 C_d A \tag{13}$$

$$F = 0.5(999)(2.235^2)(.5)(0.714) \tag{14}$$

$$F = 890.75 \text{ N} \tag{15}$$

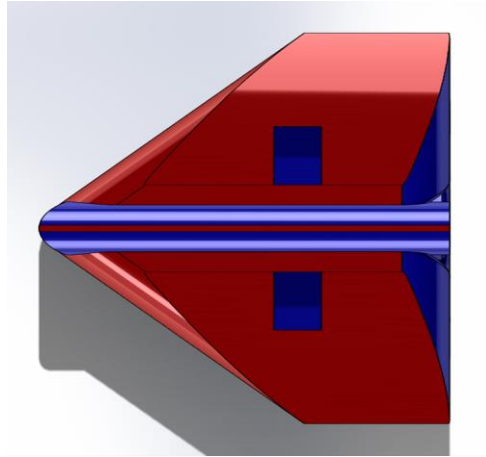

Figure 7: Final boomerang design with handlebars on the top.

6.1.2 Triton

Coefficient of Drag Assumptions

$$C_d = 0.10$$

$$A = 513.20 \text{ in}^2 = 0.3311 \text{ m}^2$$

$$\rho = 999 \frac{\text{kg}}{\text{m}^3}$$

$$V_e = 2.235 \left[\frac{\text{m}}{\text{s}} \right]$$

Coefficient of Drag Calculations

$$F = 0.5\rho V^2 C_d A \tag{16}$$

$$F = 0.5(999)(2.235^2)(.1)(0.3311) \tag{17}$$

$$F = 82.6 \text{ N} \tag{18}$$

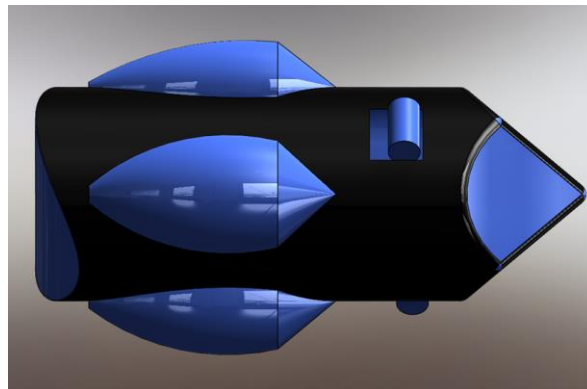

Figure 8: Final Triton design modeled after teardrop concept.

6.2.1 Power Calculations for Boomerang and Triton

The power calculations performed confirmed that the boomerang design vs. the triton design would not be as hydrodynamic; therefore, making the decision process for the final design simple.

$$V_e = 2.235 \left[\frac{m}{s} \right]$$

$$\mathcal{P}_d = \mathbf{F}_d \cdot \mathbf{v} \quad (19)$$

$$= \frac{1}{2} \rho v^3 A C_d \quad (20)$$

$$\mathcal{P}_{d(\text{boomerang})} = 1990.82W = 2.669hp \quad (21)$$

$$\mathcal{P}_{d(\text{Triton})} = 184.611W = 0.2475hp \quad (22)$$

6.3.1 Shell Construction

The team will go ahead and proceed with a shell prototype. The team spoke with Dr. Tester and he provided points to consider. First, the team needs to find out where and how the engine will be mounted onto the shell. Also, the 3-D printer that will be used is not big enough to produce a full-scaled prototype of actual size; therefore, the shell will need to be cut into halves, possibly quarters, and shell out the inside. Each individual half, or quarter, will be printed out individually and a lip will be added to all the edges. With the edges added, the parts will be able to be assembled together, rather than having just one part printed out. Again, the prototype will be scaled down from its actual size by about 1/5 of its total ratio.

7.0 CONVERSION KIT

There are machining operations that need to be made to the engine in order for the kit to work properly, that group members will undertake in the NAU machine shop. The Altfuel kit is the best option because there are training instructions and example video clips that can be found online. The machining operations conducted in the machine shop will reduce the overall cost of designing the engine to run on propane.

After researching several conversion kits, the group purchased the Altfuel system shown in Figure 9. The system contains several components including:

- Intake Adaptor
- Bracket for Tank
- Regulator
- Attachment Line
- Fuel Line



Figure 9: Propane Conversion Kit Components
propanepowerkits.com

8.0 Testing

The testing of the engine will be conducted in several stages. The initial stage will be to test for the efficiency of the engine using gasoline. After this is analyzed, the engine will need to be tested for emissions, which is discussed in the next section. The emissions must show the viability of the engine in regards to current marine board engine regulations. Secondly, the engine will be modified and then tested with the new alternative fuel.

All the aspects of testing (i.e. thrust, weight, and functionality of all parts, fuel efficiency, emissions and buoyancy) will take place during the current semester.

8.1.1 Testing Facility

The new design for the Aqua Scooter will require a specific testing apparatus which will allow the team to determine thrust, buoyancy, and measure emissions. The testing apparatus needs to have some form of strain gauges that the design can pull against and the entire system will need to be submerged under a few inches of water. Two potential options for making the apparatus include a large aquarium and a trough pool.

An aquarium would need to be at least 150 gallons to accomplish full submersion and have adequate space to set up the gauges to measure thrust.



Figure 10: Fish Tank for Thrust and Power Testing

The trough pool, which is used generally to bathe ranch animals on the size of cows, should be large enough to set up the thrust measurement system while also being deep enough to submerge the new design. The team is currently inquiring within the CEFNS department of NAU to find a suitable aquarium that can be used for the testing process.



Figure 11: Water Trough for Thrust and Power Testing

8.2.1 Power Output Testing

In order to test the power output of the engine for each fuel type, a Prony brake will be constructed. A Prony brake measures the force differential by using spring or deflection meters that are attached to a strap that is wrapped around a pulley that is attached to the engine crankshaft. The force differential, along with the linear distance the pulley traveled, divided by the time the procedure took place will yield the power

output of the engine. A dimensionless form of the power formula is below in Equation 23. During the procedure, the efficiency for each fuel test will be assumed equal as it will allow for an accurate comparison basis for each fuel. A Prony brake similar to the one used for this project is in Figure 12.

$$P = \frac{(F_A - F_B) * D}{t} \quad (23)$$

Where:

P = Engine Power

F_i = Force measured from each gage

D = Linear Distance Traveled by Pulley

t = time

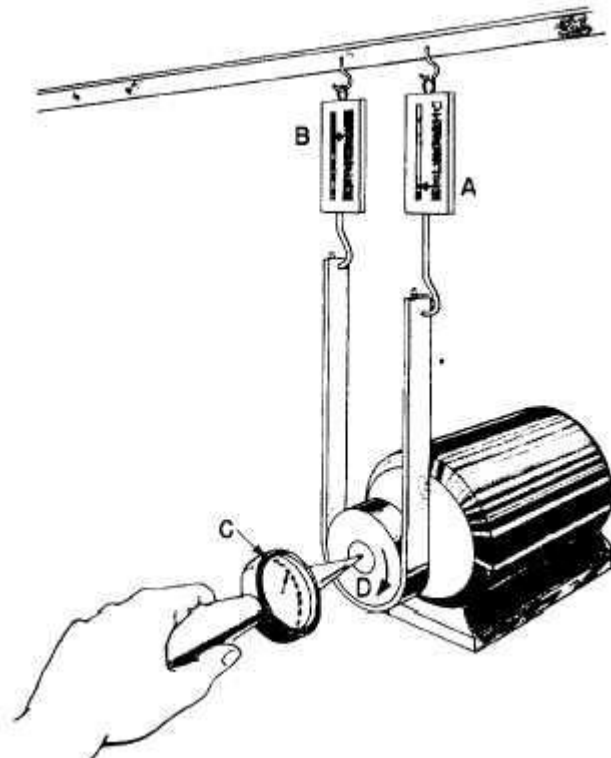

Figure 12: Prony Brake Setup [21]

8.3.1 Thrust Output Testing

The team will be using a fish scale to measure the thrust given off by the engine. The fish scale will be attached to the motor, and the motor will be attached to a propeller that will cause the thrust force. The testing will be done underwater, and while the engine stays afloat it will be run to cause motion in the propeller. The original weight

on the scale before the propeller begins is assumed to be zero. The weight after it has reached full thrust will be recorded and the overall thrust will be calculated.

8.4.1 Emissions Testing

Multiple options of emissions testing locations and devices were researched. The first company contacted was Carnot Emission Testing Services (210-928-1724). This company quoted a price of \$5000 to do the emission testing and help get the product through the EPA regulations process. Olson-Ecologic Engine Testing Laboratories (714-774-3385) was also contacted with similar results.

It was determined that a 5-gas analyzer, shown in Figure 13, is needed to perform the proper emissions tests on the motor. A 5-gas analyzer is an apparatus which determines the composition of gasses in an exhaust system[22]. The amount of the gases HC , CO , CO_2 , O_2 , and NO_x are measured from the tailpipe of a vehicle. Although this will not be an EPA certified measurement, it will give the team the proof of concept needed to proceed with the project in confidence.



Figure 13: Five Gas Analyzer

After searching for an inexpensive analyzer on the internet, it was found that the cost of such an apparatus is prohibitive (Appendix E). As an alternative, multiple auto shops and mechanics were contacted in the Flagstaff and Sedona area. Due to the lack of emissions testing in Coconino County only one facility, Flagstaff Auto Repair had the required gas analyzer. The analyzer is usually used on a car by connecting the reader to the muffler to measure the exhaust as it exits the tail pipe.

The type of motor needing to be tested was discussed with Flagstaff Auto Repair and it was decided that a pipe will need to be temporarily fitted to the head of the engine to serve the purpose of an exhaust system. At that time, the employee that was discussing the matter stated he did not know more of the details and that his coworker would be the person in charge of the process. Flagstaff Auto Repair is scheduled to call us back to discuss costs and logistics of the testing. It is believed at this time that the cost will be low and that this provides the mechanism to perform all necessary emissions tests of the motor.

10.0 COST ANALYSIS

In order to organize the potential costs for testing the selected solutions, Table 1, was constructed. The materials are broken down into two columns, budget costs and actual costs. As the project culminates the cost of items purchased and anticipated are adjusted. The category, which accounts for the highest percentage of total cost, is the purchase cost of the conversion kit. The budgeted amount was considerably less than the actual cost. This is balanced out by the emissions budgeted cost and the quoted cost provided by the local provider. The client did request costs of more comprehensive emissions testing which was discussed earlier. The reason for this inquiry is, the final prototype may be tested using the more expensive and comprehensive testing facilities.

Table 1: Cost of Materials for Testing Engines

Item	Budget Costs	Actual Costs	% of Total	% of Total
Conversion Kits	\$200.00	\$363.00	9.69%	28.58%
Emission Testing	\$1,000.00	\$50.00	48.43%	3.94%
Testing Environment	\$175.00	\$175.00	8.47%	13.78%
2-Stroke Engine	\$200.00	\$169.00	9.69%	13.31%
4-Stroke Engine	\$240.00	\$263.00	11.62%	20.71%
Shipping of Engines	\$75.00	\$75.00	3.63%	5.91%
Shell Prototype	\$50.00	\$50.00	2.42%	3.94%
Oil	\$25.00	\$25.00	1.21%	1.97%
Butane Gas	\$50.00	\$50.00	2.42%	3.94%
Propane Gas	\$50.00	\$50.00	2.42%	3.94%
	\$2,065.00	\$1,270.00		

The pie chart shown in Figure 14 provides a visual representation of the potential costs associated with the testing of the two engines selected. The cost of the engines, account for 21% of the total cost for all materials. Again, it needs to be stated that the percentages are relative considering the high cost of emissions testing provided in the table.

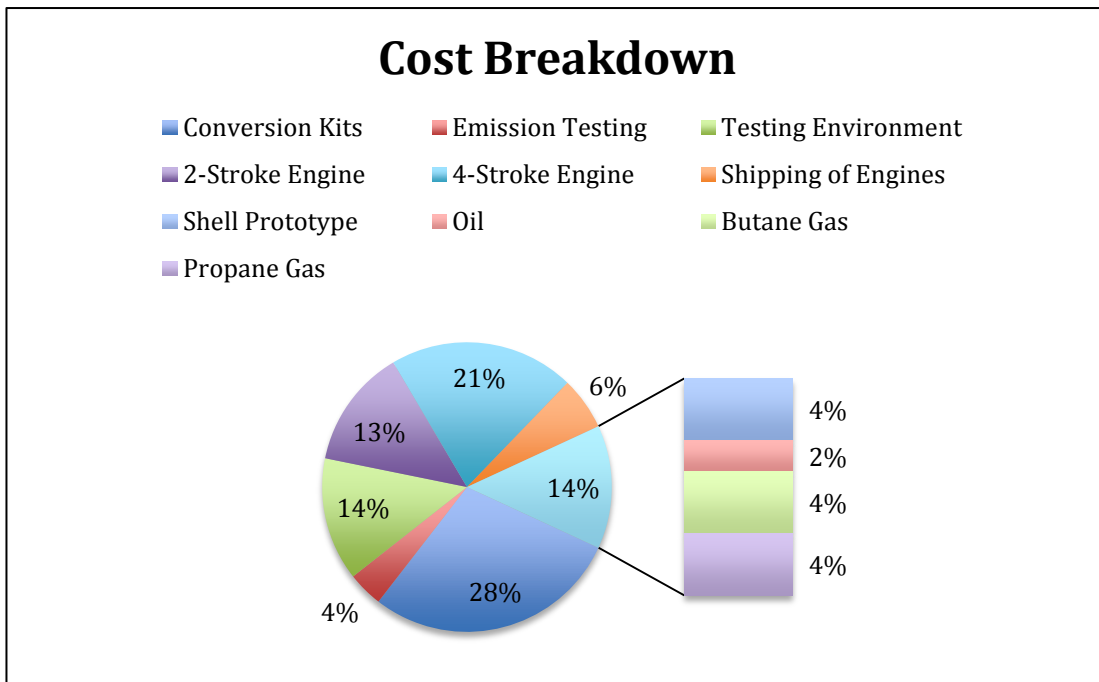

Figure 14: Pie Chart with Percentages of Total Cost

11.0 CONCLUSION

The client, R.S.W. /D.I. Inc. currently manufactures a product that does not meet current United States’ EPA regulations. The objective of this project is to design, engineer, and test an engine that will exceed the current EPA regulations. The most important points to consider for the design of a prototype are to adhere to the EPA regulations, keep dry weight of device under 18 lbs. and provide a capacity of a minimum of 50 lbs. of thrust. Additionally, the team must keep the manufacturing cost per scooter under \$450. The team’s decision matrix assisted in providing potential solutions for the client. Two concepts were selected and were analyzed to assess feasibility.

After some primary calculations, the two-propeller design was ruled out and a single propeller was chosen for full analysis. The engine chosen for analysis was the 4-stroke Honda GXH50 engine. The feasibility of using butane and propane gases for engine was calculated and researched. The calculations show that both of these gases are able to propel the Aqua Scooter effectively.

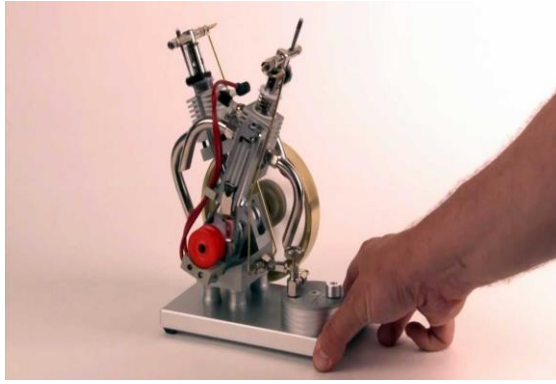

Figure 15: Possible engine design converted for gas fuel.

The final design selected for further testing is the Triton shown in Figure 16.

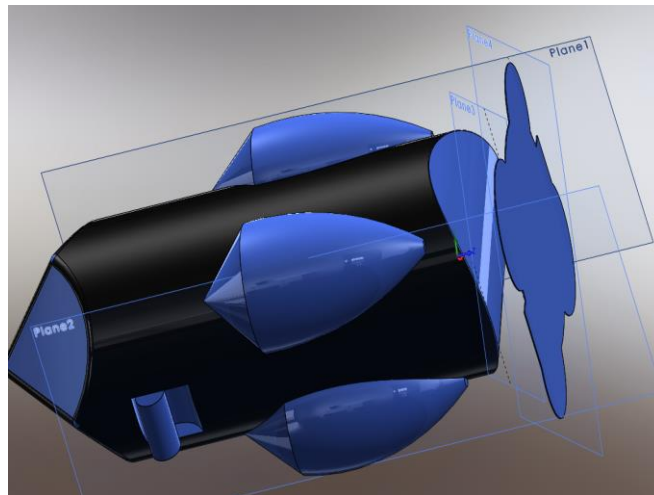

Figure 16: Final Triton design with area used for analysis

The engine selected for purchase was the Honda GX-25. This engine is currently being shipped to the school. The propane conversion kit has already arrived and is ready to be fitted onto the Honda engine after initial analysis is conducted.

The team will need to test the amount of power and thrust the engine is providing with the current gasoline fuel. This line of analysis will provide the team with a baseline for when the engine is converted. The engine will also need to have emissions testing done prior to the conversion.

All tests will need to be repeated after conversion utilizing the new fuel option. This is where the team will need to construct accurate and viable models for testing. The emissions testing will be conducted following several iterations of engine modeling.

A prototype of the outer shell will be constructed for the client to present to potential manufacturers. The prototype will be 3-D printed in the manufacturing lab. Although there will be a prototype the shell analysis will be conducted in ANSYS and Workbench. . .

REFERENCES

- [1] Aqua Scooter Manual. Comer SPA. Accessed 10 Oct 2014.
http://www.aquascooter.it/AQUA_GB.pdf
- [2] B. Douville, P. Ouellette, A. Touchette and B. Ursu, "Performance and emissions of a two-stroke engine fueled using high-pressure direct injection of natural gas," in *1998 SAE International Congress and Exposition, February 23, 1998 - February 26, 1998*, .
- [3] P. Duret, A. Ecomard and M. Audinet, "A new two-stroke engine with compressed-air assisted fuel injection for high efficiency low emissions applications," in *International Congress and Exposition, February 29, 1988 -March 4, 1988*, .
- [4] H. Huang, M. Jeng, N. Chang, Y. Peng, J. H. Wang and W. Chiang, "Improvement of exhaust emissions from a two-stroke engine by direct injection system," in *International Congress and Exposition, March 1, 1993 -March 5, 1993*,
- [5] W. Mitianiec, "Direct injection of fuel mixture in a spark ignition two-stroke engine," in *SAE 2002 World Congress, March 4, 2002 - March 7, 2002*, .
- [6] K. Morikawa, H. Takimoto, T. Kaneko and T. Ogi, "A study of exhaust emission control for direct fuel injection two-stroke engine," in *Small Engine Technology Conference and Exposition, September 28, 1999 -September 30, 1999*, .
- [7] P. Rochelle and W. Perrard, "Fuel consumption and emission reduction of a small two-stroke engine through air-assisted fuel injection and delayed-charging," in *International Congress and Exposition, March 1, 1999 -March 4, 1999*,.
- [8] Sea-Doo. (2013) *RS Comparison* [Online]. Available FTP:
http://www.seadooseascooter.com/RS_CMS/index.php?option=com_content&view=article&id=22&Itemid=41
- [9] A. Dave, Development of a Reed Valve Model for Engine Simulations for Two-Stroke Engines, 1st ed. , SAE International, 2004.
- [10] L. Arnone, M. Janeck, M. Marcacci, R. Kirchberger, M. Pontoppidan and R. Busi, "Development of a direct injection two-stroke engine for scooters," in *Small Engine Technology Conference and Exhibition, November 28, 2001 - November 30, 2001*, .
- [11]<https://www.youtube.com/watch?v=QvUih9Y2Nmw>

- [12] <http://www.calor.co.uk/15kg-butane-gas-bottle.html>
- [13] <http://www.plastic-mart.com/category/41/plastic-stock-tanks-water-troughs>
- [14] <https://sites.google.com/a/altfuelconv.com/altfuel-llc/where-to-purchase>
- [15] https://www.propanecarbs.com/small_engines.html
- [16] <http://www.husqvarna.com/us/products/trimmers/128c/#specifications>
- [17] <http://www.tanakapowerequipment.com/main-navigation/products?d=329,341&p=878>
- [18] http://www.brandnewengines.com/21132-0559.aspx?gclid=Cj0KEQIAneujBRDcvL6f5uybhdABEiQA_ojMgghvNjmKx_PmQjxv0TEOpBZfypPHOrP6kIOj3nKbrBIaAvjO8P8HAQ
- [19] <http://engines.honda.com/models/model-detail/gx25>
- [20] <http://megadepot.com/product/enerac-500-1co-emissions-monitoring-equipment-m500>

- [21] http://enginemechanics.tpub.com/14037/css/14037_53.htm
- [22] <http://www.vehicleservicepros.com/product/10097474/emissions-systems-inc-4-5-gas-exhaust-analyzer-no-ems-5002>

APPENDIX A: Aqua Scooter Components

- 1 - AIR TANK
- 2 - AIR TANK PLUG FOR SNORKEL CONNECTION
- 3 - FUEL TANK PLUG
- 4 - FUEL TANK
- 5 - FUEL VALVE
- 6 - EXHAUST GAS OUTLET
- 7 - FUEL PIPE
- 8 - STARTER HANDLE
- 9 - STEERING HANDLE
- 10 - THROTTLE LEVER

Figure A1: List of components of Aqua Scooter

- 11 - "AVVIAMENTO - START - STOP" POSITIONS
- 12 - CARBURETTOR TO CARB - EPA STANDARDS
- 13 - "START AND RUN" LEVER
- 14 - "RUN/MARCIA" POSITIONS
- 15 - PROTECTIVE GRILLE C €
- 16 - FUEL TANK BREATHER PIPE
- 17 - PROPELLER GUARD AND WATER DEFLECTOR C €
- 18 - CARRY HANDLE
- 19 - SPARK PLUG
- 20 - AIR INTAKE TUBE (SNORKEL)
- 21 - SNORKEL EXTENSION
- 22 - RUBBER BUMPER

Figure A2: Additional list of components for Aqua Scooter

APPENDIX B: Volume Calculations for Butane and Propane

Propane

```
%Propane volume calculator

Hp = input('Enter horsepower here\n'); %User input for engine horsepower

Bhr = Hp*2544.43358; %[Btu/hr] Converts input horsepower to Btu/hr

t = 3; %[hr] Time that aquascooter needs to run from full to empty fuel tank

B = Bhr*t; %[Btu] Energy needed from propane for aquascooter to run for time
t

IE = 84250; %[Btu/gal] Internal energy of propane

V = B/IE; %[Gal] Volume of propane needed to provide the energy for the
aquascooter

rho = 65.8285503; %[oz/gal] Density of propane

W = rho*V; %Weight of propane needed to run for time t

fprintf('The weight of propane needed is %4.2f oz.\n',W);
```

Butane

```
%Butane volume calculator

Hp = input('Enter horsepower here\n'); %User input for engine horsepower

Bhr = Hp*2544.43358; %[Btu/hr] Converts input horsepower to Btu/hr

t = 3; %[hr] Time that aquascooter needs to run from full to empty fuel tank

B = Bhr*t; %[Btu] Energy needed from propane for aquascooter to run for time
t

IE = 102600; %[Btu/gal] Internal energy of butane

V = B/IE; %[Gal] Volume of propane needed to provide the energy for the
aquascooter

rho = 79.9823563; %[oz/gal] Density of butane

W = rho*V; %Weight of propane needed to run for time t
fprintf('The weight of butane needed is %4.2f oz.\n',W);
```

APPENDIX C: Thrust

```

function thrust
RPM=input('What is the required RPM?\n');
Vo=input('What is the required speed (in miles/hour) [Vo]?\n');
Vo=Vo*(0.44704);    % mi/hr ---->0.44704 m/s
P=input('What is the required Pitch [P]?\n');
F=input('What is the required minimum thrust (in lbs) [F]?\n');
F=F*(4.448);      % Lbs ----->4.448 N
syms d

d1=solve(F==1.225*(pi*(0.0254*d)^2)/4*((RPM*0.0254*P*(1/60))^2-
(RPM*0.0254*P*(1/60))*Vo)*(d/3.29546*P)^1.5,d,'Real',true);
d2=solve(F==4.392399e-8*RPM*(d^(3.5)/sqrt(P))*(4.23333e-4*RPM*P-
Vo),d,'Real',true);
fprintf('The full equation gives the diameter needed as %g \n',double(d1));
fprintf('The short equation gives the diameter needed as %g \n',double(d2));

```

APPENDIX D: Adiabatic Flame Temperatures using interactive thermodynamics

TR = 50 // sea water temp in F

//Propane analysis for adiabatic flame temp
 //evaluate reactant and product enthalpies hR and Hp
 $hR = h_{C3H8} + 5 \cdot h_{O2_R} + 18.8 \cdot h_{N2_R}$
 $hP = 3 \cdot h_{CO2_P} + 4 \cdot h_{H2O_P} + 18.8 \cdot h_{N2_P}$

$h_{C3H8} = -44680$
 $h_{O2_R} = h_T("O2", TR)$
 $h_{N2_R} = h_T("N2", TR)$
 $h_{CO2_P} = h_T("CO2", TP)$
 $h_{H2O_P} = h_T("H2O", TP)$
 $h_{N2_P} = h_T("N2", TP)$

$hP = hR$
 TP = 3833 // adiabatic flame temp in F
 ///
 TR = 50 // sea water temp in F

//Butane analysis for adiabatic flame temp
 //evaluate reactant and product enthalpies hR and Hp
 $hR = h_{C3H8} + 9 \cdot h_{O2_R} + 33.84 \cdot h_{N2_R}$
 $hP = 4 \cdot h_{CO2_P} + 10 \cdot h_{H2O_P} + 33.84 \cdot h_{N2_P}$

$h_{C3H8} = -44680$
 $h_{O2_R} = h_T("O2", TR)$
 $h_{N2_R} = h_T("N2", TR)$
 $h_{CO2_P} = h_T("CO2", TP)$
 $h_{H2O_P} = h_T("H2O", TP)$
 $h_{N2_P} = h_T("N2", TP)$

$hP = hR$
 TP = 3931 // adiabatic flame temp in F
 ///
 TR = 50 // sea water temp in F

//Propane analysis for adiabatic flame temp
 //evaluate reactant and product enthalpies hR and Hp
 $hR = h_{C8H18} + 12.5 \cdot h_{O2_R} + 47 \cdot h_{N2_R}$
 $hP = 8 \cdot h_{CO2_P} + 9 \cdot h_{H2O_P} + 47 \cdot h_{N2_P}$

$h_{C8H18} = -107530$
 $h_{O2_R} = h_T("O2", TR)$
 $h_{N2_R} = h_T("N2", TR)$
 $h_{CO2_P} = h_T("CO2", TP)$
 $h_{H2O_P} = h_T("H2O", TP)$
 $h_{N2_P} = h_T("N2", TP)$

$hP = hR$
 TP = 3833 // adiabatic flame temp in F

APPENDIX E: Quotes for Emissions Equipment

Inquiry Date 21-Jan-15		Inquiry Reference No. v.15	Shipping Terms ExWorks Niagara Falls, NY	FUNDS US \$
Item No.	Qty.	Description	Unit Price	
1	1	<p>Nova Model 7466K Portable 6 Gas Engine Exhaust Analyzer for CO, CO2, HC's, O2, NO, & NO2.</p> <ul style="list-style-type: none"> - NDIR infra red CO, CO2 & Hydrocarbon (HC's) detectors - long life electrochemical O2, NO & NO2 sensors - portable analyzer, suitable for temporary / intermittent analysis - ranges : 0 - 5.00 / <u>10.00</u> % CO (*choose one) 0 - <u>20.0</u> % CO2 0 - 1,999 up to <u>9,999</u> PPM HC's (as Hexane) (other ranges & HC's as Propane available) 0 - <u>25.0</u> % Oxygen 0 - <u>2,000</u> / 5,000 PPM NO (*choose one) 0 - 200 / 500 / <u>800</u> PPM NO2 (*choose one) - displays : digital, one per gas analyzed - operation : re-chargeable 'gel cell' battery, DC and AC - power : 115VAC / 60 Hz. Re-charger and 12VDC cigarette lighter plug supplied loose. - sampling : built-in sample pump, filter and flow meter; automatic condensate removal system. S.S. probe & flexible hose supplied loose. - enclosure : 'K' series suit case style polycarbonate, black * Standard ranges above are <u>under-lined</u>. <p><u>Also available in the following popular combinations :</u></p>	\$9,150.00	
2	1	<p>Nova Model 7466K Portable 6 Gas Engine Exhaust Analyzer for CO, CO2, HC's, Oxygen, NO and NO2</p>	\$9,150.00	
3	1	<p>Nova Model 7465K Portable 5 Gas Engine Exhaust Analyzer for CO, CO2, HC's, Oxygen & NO.</p>	\$7,525.00	

4	1	Nova Model 7464K Portable 4 Gas Engine Exhaust Analyzer for CO, CO ₂ , HC's & Oxygen.	\$6,300.00
5	1	Nova Model 7463K Portable 3 Gas Engine Exhaust Analyzer for CO, CO ₂ & HC's.	\$5,450.00
6	1	Nova Model 7462K Portable 2 Gas Engine Exhaust Analyzer for CO & HC's.	\$4,950.00
7	1	Nova Model 7461AK Portable 1 Gas Engine Exhaust Analyzer for CO.	\$4,550.00
8	1	Nova Model 7461CK Portable 1 Gas Engine Exhaust Analyzer for HC's.	\$4,550.00
		Options	
9	1	Built-in Printer. - add a " P " suffix to Model #...ie Model 7466K becomes Model 7466PK - printout header contains 24 characters, spaces included. Specify header text on PO.	\$550.00
10	1	Low Range PPM CO Channel by Electrochemical CO sensor in place of NDIR % CO detector. - range : 0 - 2,000 / 5,000 / 10,000 PPM CO* (10 PPM Res.) * choose one range & specify on PO - add an "L" suffix to Model #. ie. Model 7466LK	\$25.00
11	1	Add Nitrogen Oxide Channel to any 7460 series analyzer - range : 0 - 2,000 / 5,000 PPM NO (* choose one) - add an "N" suffix to Model #. ie Model 7461NK	\$1,360.00
12	1	Add Nitrogen Dioxide Channel to any 7460 series analyzer - range : 0 - 200 / 500 / 800 PPM NO ₂ (* choose one) - add an "X" suffix to Model #. ie Model 7461XK	\$2,090.00
13	1	Serial Output & Data Logging PC Software Package - real-time data logging of analyzer results - communication format un-pollled (half duplex) RS-485 - RS-485 to USB Adapter Plug / Cable Assembly included.	\$495.00
14	as req'd	4 - 20mA recorder output , max. one per gas analyzed	each \$95.00

<u>Probe Choices</u>			
15	1	Standard Probe with S.S. Flex Tip , cool-touch handle & sample hose - for gasoline, LPG & clean-burning diesel - for light to medium particulate load, small pre-filter - for up to 400° F Automobile applications c/w full exhaust	standard probe included
16	1	Probe with S.S. Straight Tip , cool-touch handle & sample hose - for gasoline, LPG & clean-burning diesel - for light to medium particulate load, small pre-filter - for up to 1,200° F Forklift applications.	no charge in place of standard probe
<u>Spares</u>			
1	1	Water Separator Element - 25-51-70K	\$11.00
2	1	In-line Filter - IDN6G	\$21.00
3	1	PTFE Liquid Blocker - ACRO37-PTFE	\$28.00
4	1	Probe Filter (Package of 20) - AGS-011	\$140.00
5	1	Rolls paper, 5 pack	\$25.00
6	1	Oxygen Sensor - KE25-F3	\$225.00
7	1	NO Sensor - 5NF	\$415.00
8	1	NO2 Sensor - 5ND	\$415.00

Thank you for the opportunity to quote on your requirements.
NOVA ANALYTICAL SYSTEMS

[Additional Information](#)

Prepared by:
 David Sheasby



ESTIMATED SHIPPING SCHEDULE
 AT TIME OF QUOTE
 6 - 8 WEEKS